

CHAPTER IV- FORCE SYSTEM RESULTANTS-

F4-5. Determine the moment of the force about point O . Neglect the thickness of the member.

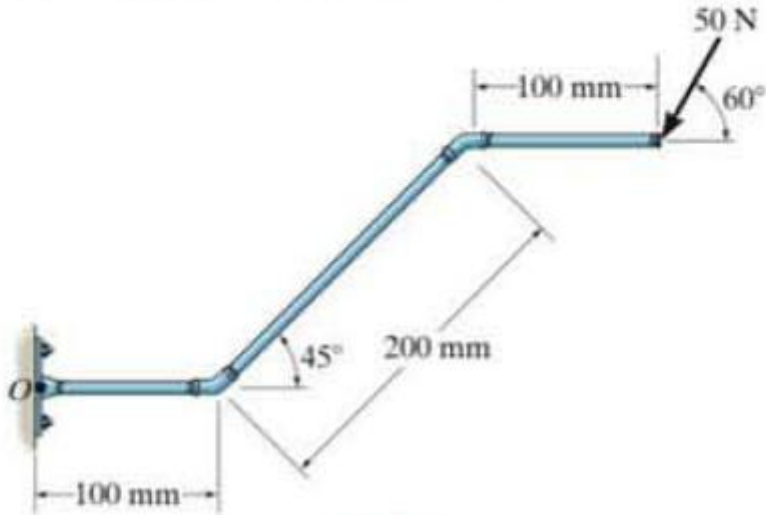

F4-8. Determine the resultant moment produced by the forces about point O .

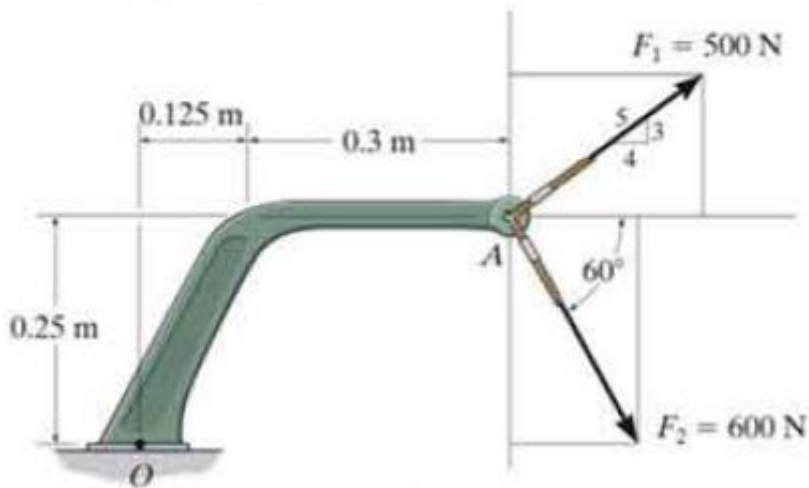

F4-8

- 4-33. The towline exerts a force of $P = 4 \text{ kN}$ at the end of the 20-m-long crane boom. If $x = 25 \text{ m}$, determine the position θ of the boom so that this force creates a maximum moment about point O . What is this moment?

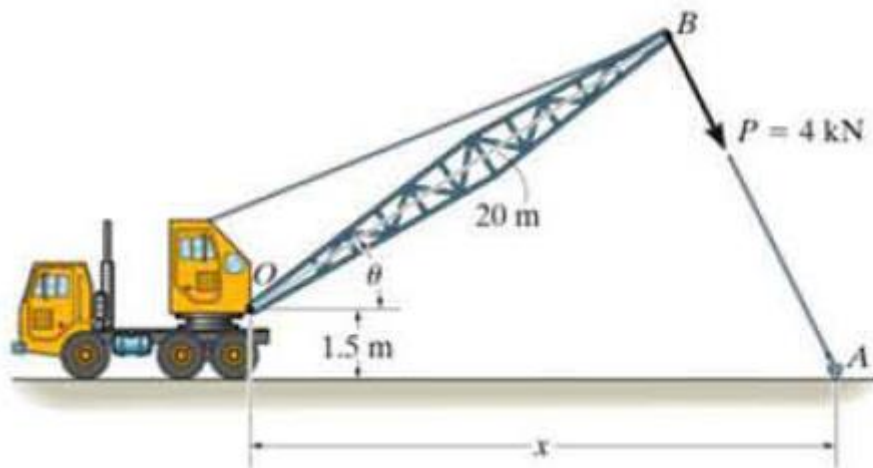

- *4-36. The wheelbarrow and its contents have a center of mass at G . If $F = 100 \text{ N}$ and the resultant moment produced by force \mathbf{F} and the weight about the axle at A is zero, determine the mass of the wheelbarrow and its contents.

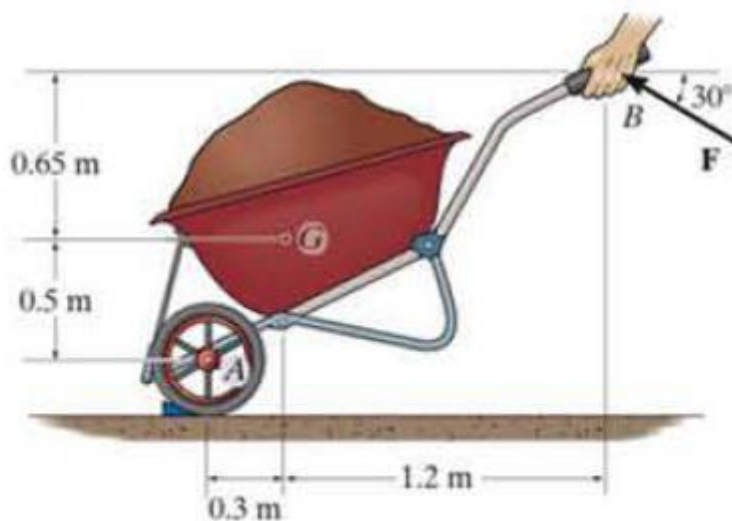

F4-22. Determine the couple moment acting on the beam.

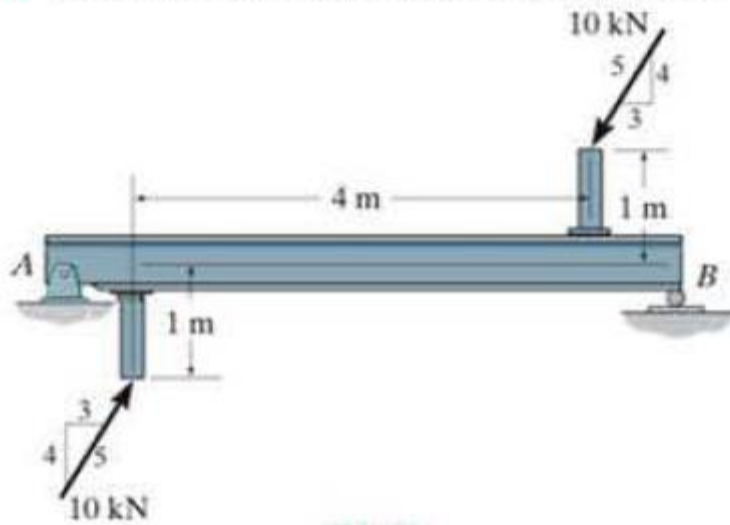

F4-21. Determine the magnitude of F so that the resultant couple moment acting on the beam is $1.5 \text{ kN} \cdot \text{m}$ clockwise.

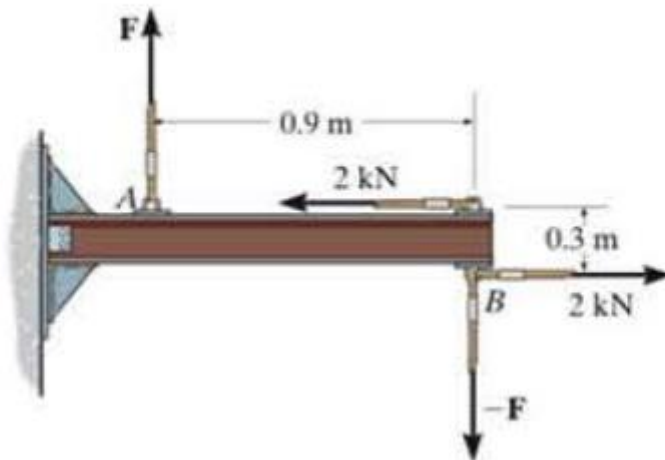

- 4-85. Determine the resultant couple moment acting on the beam. Solve the problem two ways: (a) sum moments about point O ; and (b) sum moments about point A .

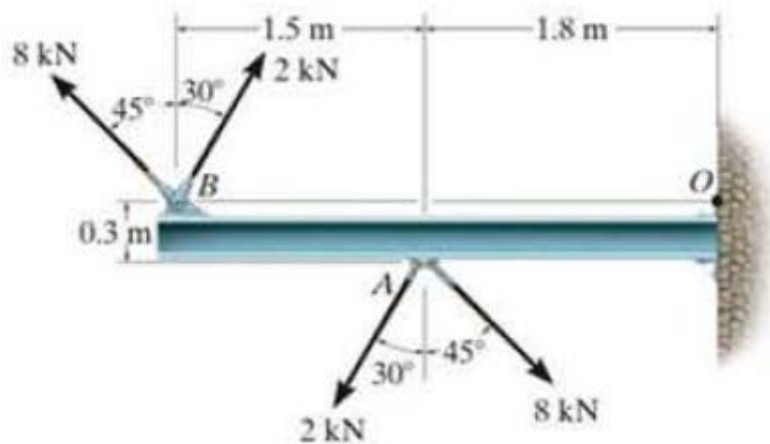

- 4-87. Determine the required magnitude of force F , if the resultant couple moment on the beam is to be zero.

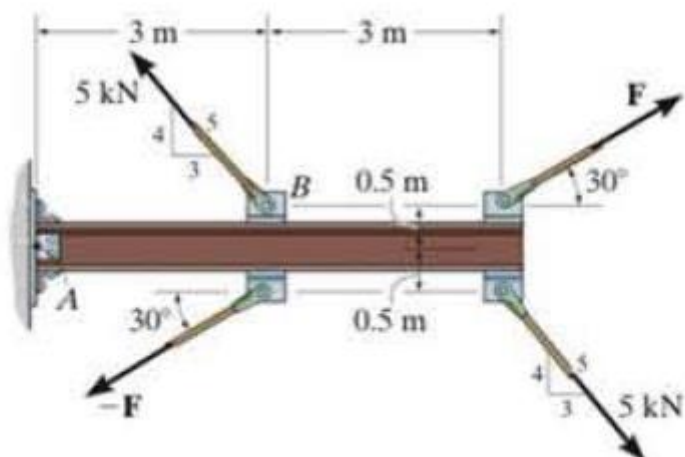

F4-26. Replace the loading system by an equivalent resultant force and couple moment acting at point *A*.

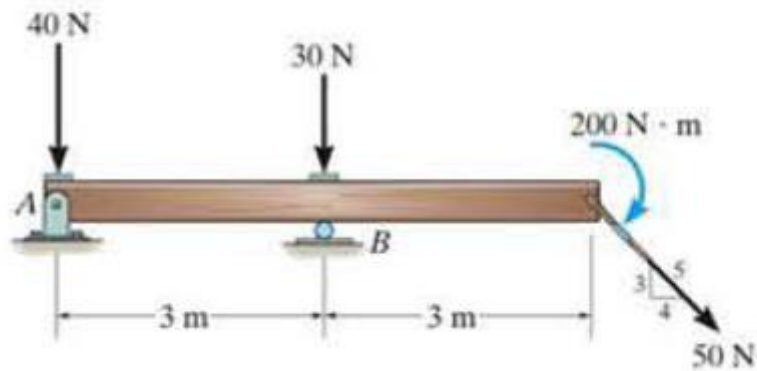

4-106. Replace the force system acting on the beam by an equivalent force and couple moment at point *B*.

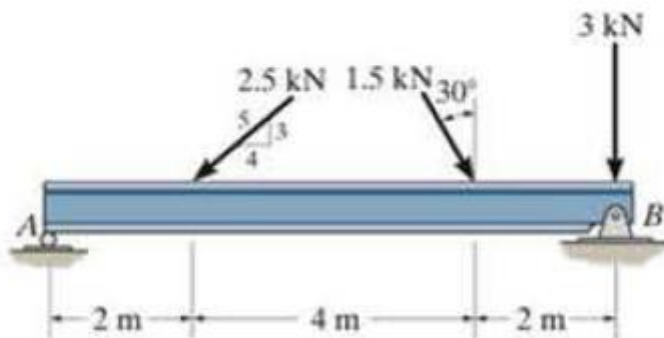

- 4-109. Replace the force system acting on the post by a resultant force and couple moment at point A .

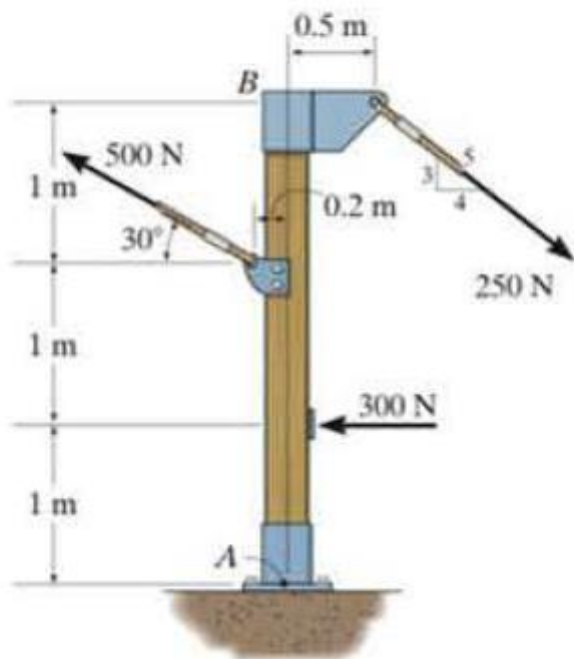

4-III. Replace the force system by a resultant force and couple moment at point O .

